

PANORAMA MOTORIZED RECESSED MOUNT

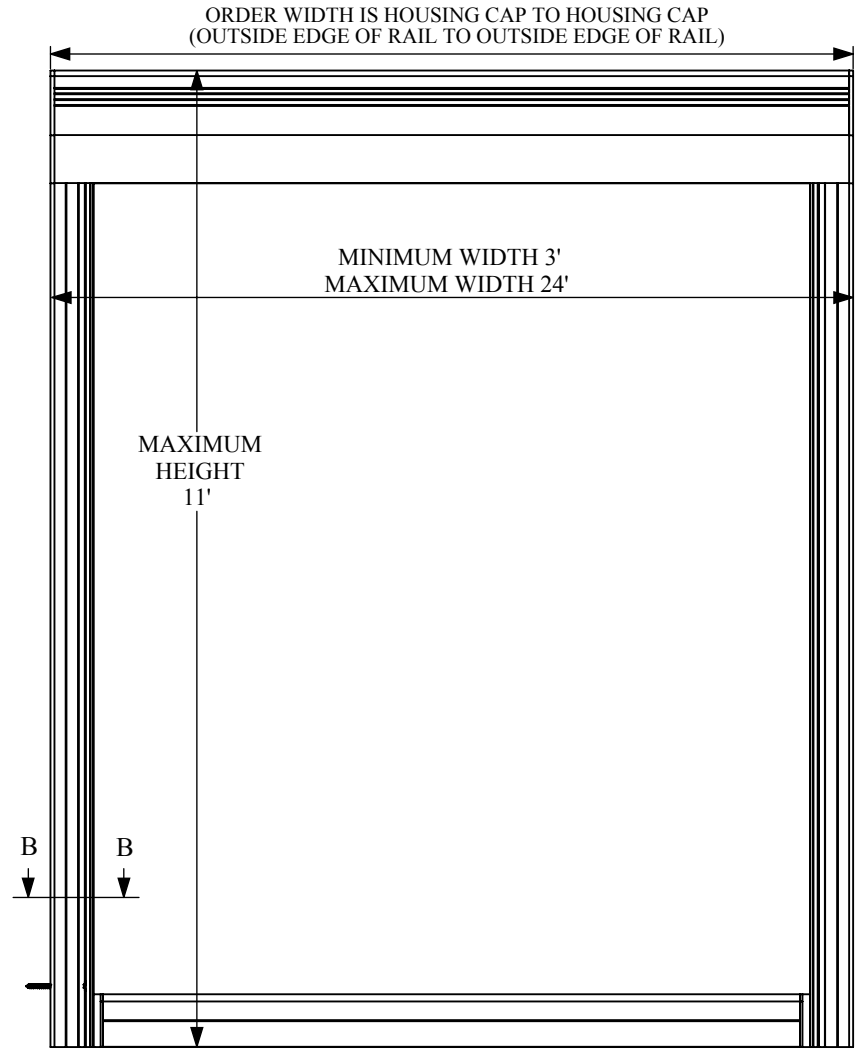

NO.#	DESCRIPTION	QTY.
1	Housing Back	1
2	Front Cover	1
3	Pull Bar Cap - Left	2
4	Pull Bar Cap - Right	2
5	Crossbar	1
6	Roll Tube	1
7	Rail	2
8	Idler Bracket	1
9	Nylon Bearing	1
10	Stainless Steel Guide	2
11	Power Cord	1

MOTOR SPECS	MOTOR	VOLTS	AMPS	Hz	TORQUE IN/LBS	RPM
	535A2	120 VAC	2.1	60	308	20

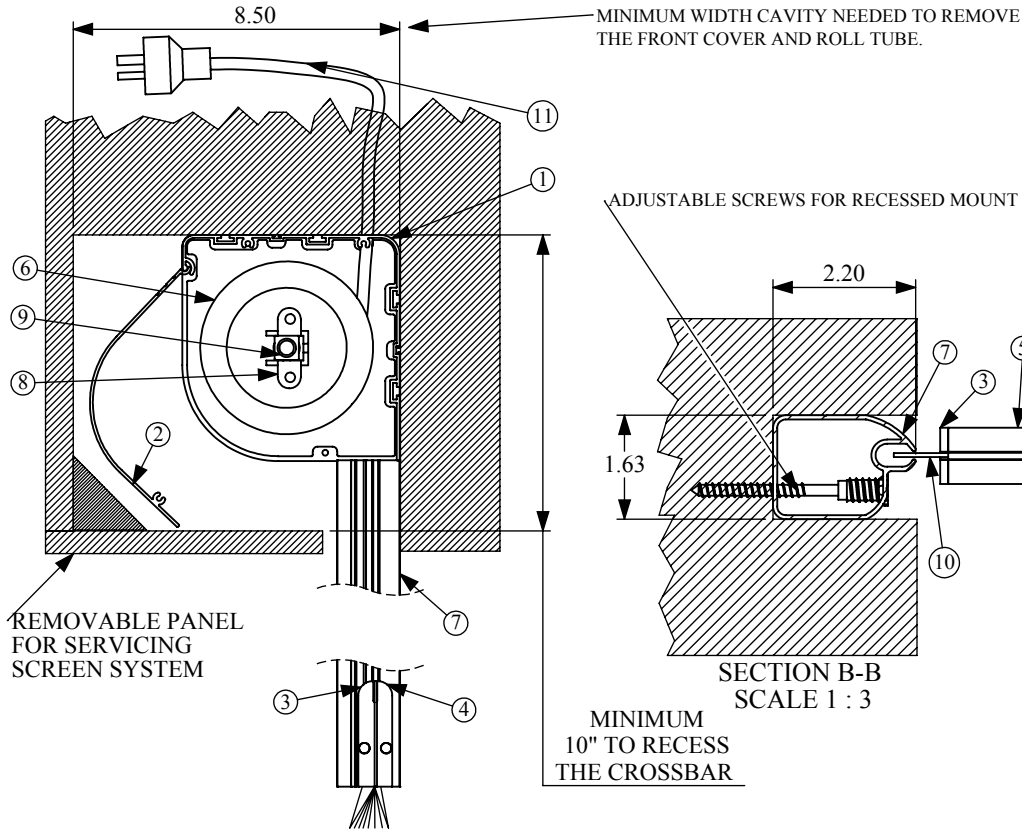
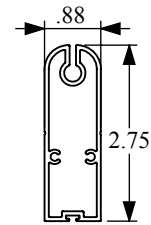

CROSSBAR

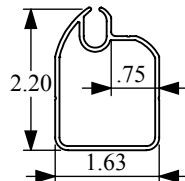

RAIL

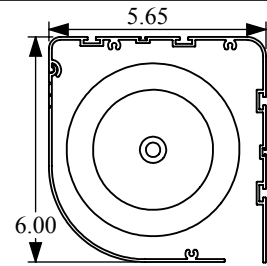

HOUSING/ ROLL TUBE

STOETT
INDUSTRIES

PANORAMA RECESSED MOUNT

SIZE A	DWG. NO.	REV. A1 1-20-10
SCALE: 1:20	WEIGHT:	SHEET 1 OF 1